

Facade Signboard of a Convenience Store

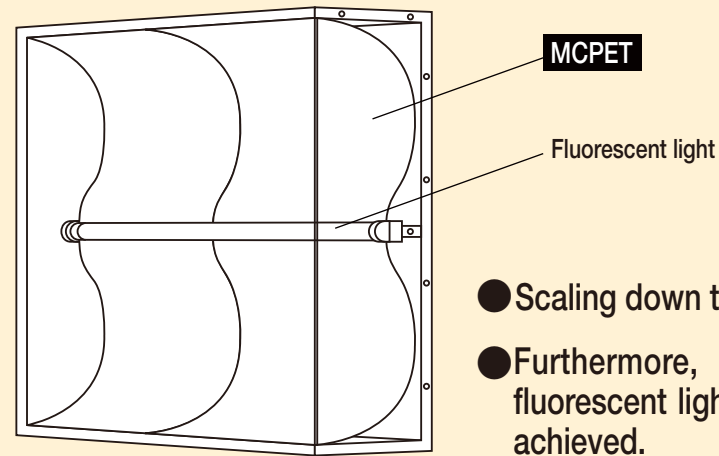

50% to 70% reduction of the energy needed for a conventional facade signboard.

- Scaling down to a one-light system saves 50% energy.
- Furthermore, when used with an energy-saving fluorescent light, a total energy saving of 70% can be achieved.

Thin Signboard

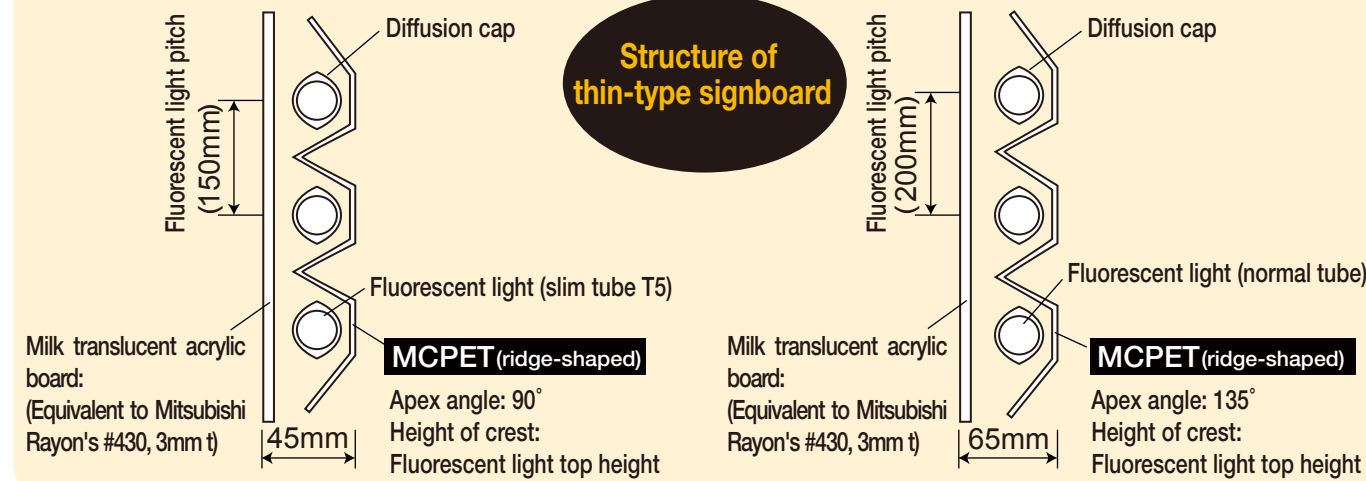

Structure of thin-type signboard

MCPET (ridge-shaped)  
Apex angle: 90°  
Height of crest: Fluorescent light top height

MCPET (ridge-shaped)  
Apex angle: 135°  
Height of crest: Fluorescent light top height

LED planar light source (backlight and signboard)

- Reduces uneven light output.
  - Reduces fluctuations in light output
  - Thin structure is possible.
  - The number of LEDs can be reduced if the board is constant in thickness.
- Note: Use LEDs with a wide angle of visibility.

Structure of LED planar light source

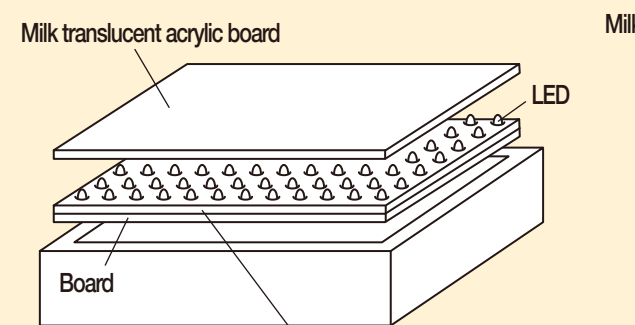

MCPET (perforated product)

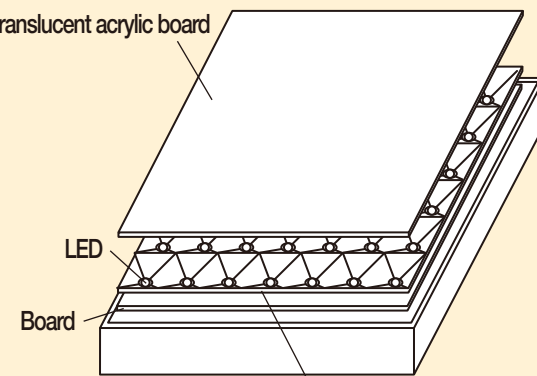

MCPET (inverted pyramid shape)

MCPET Sheet Properties

Item	Direction	Unit	Value	Test method	
Density	—	kg/m <sup>3</sup>	325	JIS K 6767	
Ave. foam size	—	μm	10 or less	ASTM-D3576-77 compliant	
Optical properties	Total reflectance	—	99	Relative to barium sulfate at 530 nm wavelength	
	Diffused reflectance	—	96		
Mechanical properties	Tensile strength	MD	13.5	JIS K 6767	
		TD	13.5		
	Elongation	MD	85	JIS K 6767	
		TD	105		
	Tear strength	MD	750	JIS K 6767	
		TD	750		
Flexural strength	MD	13.5	JIS K 7171		
	TD	13.0			
	TD	850			
Flexural modulus	MD	800	JIS K 7171		
	TD	800			
Electrical properties	—	Ω	3×10 <sup>11</sup>	JIS K 6911	
Thermal properties	Ave. linear expansion	MD	5.0×10 <sup>-3</sup>	JIS K 7197 (20~100°C)	
		TD	5.5×10 <sup>-3</sup>		
	Thermal deformation	100°C	MD	-1.1	JIS K 6767 compliant
			TD	-0.8	
			TD	-5.5	
	Heat deformation temperature (100g)	—	°C	177	JIS K 7196 compliant
—		W/mK	0.06	Heat flow meter	

Certified by UL94-HBF

Product Specifications

Grade	Thickness (mm)	Width (mm)	Length (m)	Packing
RB (Standard)	1.0	600	20	Rolled sheet (box)
RB (Standard)	1.0	600	1.5	Cut sheet (cardboard box)
RB (Standard)	1.0	600	1.2	
RB (Standard)	1.0	600	1.0	

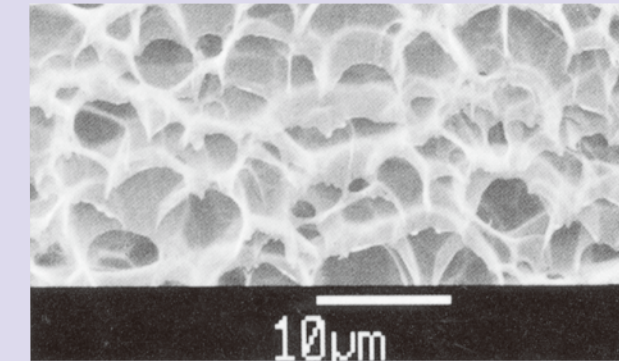

- All data is based on standard grade
- Reflectance is relative to barium sulfate white panels
- Data is based on our best estimates and is not guaranteed
- Information in this catalogue is subject to change without notice
- Product and company names included in this catalogue are registered trademarks of the respective companies

New Material for Illuminated Panels  
Microcellular Reflective Sheet

MCPET

- Contributes bright internally lit sign panels with improved sign surfaces
- Cuts energy cost of facade signs by 50%
- Reduces illumination blurs (striped patterns of lamps)
- Reduces illumination blurs and color variations in LED planar light sources (backlights and sign panels)



● Walkway to Tokyo Opera City (Hatsudai Station on the Keio New Line)

● Sign in Kyoto Station (Tokaido Shinkansen)

For further information contact:

**FURUKAWA ELECTRIC**

THE FURUKAWA ELECTRIC CO., LTD.

Foamed Products Division <http://www.furukawa.co.jp/foam/>

2-3, Marunouchi 2-chome, Chiyoda-ku, Tokyo, Japan 100-8322 Tel. +81-3-3286-3458 Fax. +81-3-3286-3472

FURUKAWA ELECTRIC

Superior Illumination of Microcellular PET Sheet

# MCPET Realizes Bright, Vivid Displays

## 1 Reflectance is increased 99%, of which 96% is diffused reflection. Reflection is balanced between blue and red light.

As the diffused reflectance of mirrored or metallic reflection panels is less than 10%, such panels are only able to reflect the light source in a specified direction. Moreover, metallic reflection panels absorb red light, changing the color of the reflected light to a bluer tint than the original light source. Since the reflectance ratios low to begin with, the reflected light becomes dark and bluish. As can be seen in the figure below, MC-PET reflects blue light with wavelengths of 400 nm and red light with wavelengths of 700 nm nearly equally, allowing the production of very bright sign surfaces.

Superior reflectance results in bright sign surfaces.

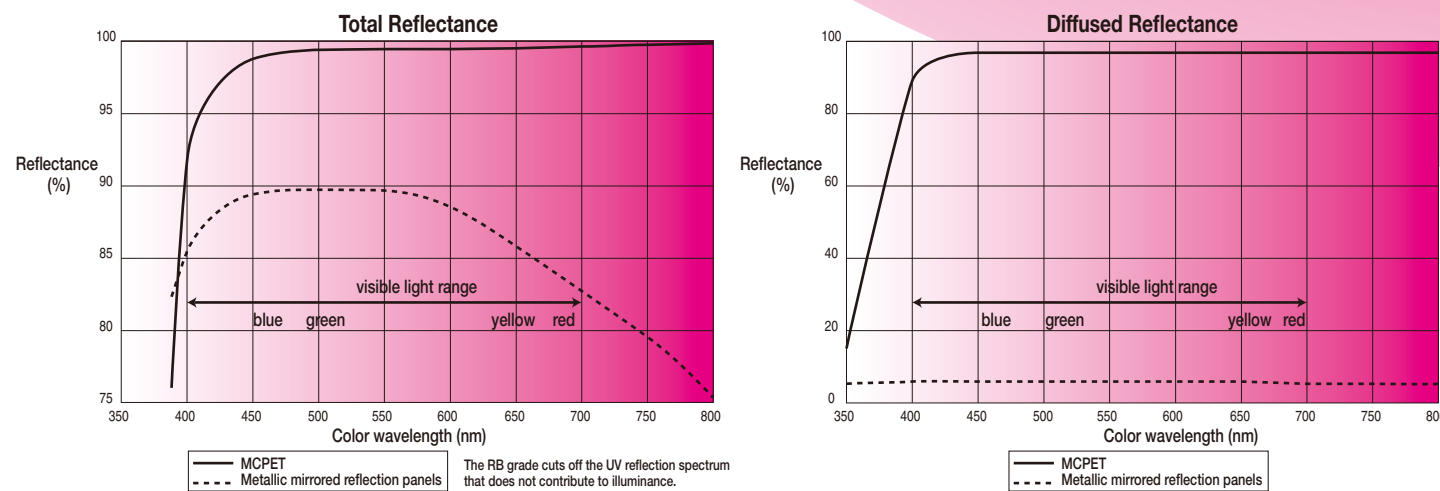

## 2 Energy costs can be reduced by 50% for facade signs and 30% for conventional signs.

- By placing MC-PET reflection panels not only behind but also above, below and beside fluorescent lights, necessary lighting can be reduced from two rows of 40 watt lights for a facade sign with a 1100 mm width. See the figure below left for an example of results.
- For a conventional sign using lighting of seven fluorescent lights per 2m<sup>2</sup> (1.5m x 1.2m), the use of MC-PET reflection panels reduces the necessary lighting to five lights per 2m<sup>2</sup>. The cost savings reflect the reduction of one fluorescent light bulb per square meter of lighting. See the figure below right.

High reflectance reduces necessary lighting to save energy.

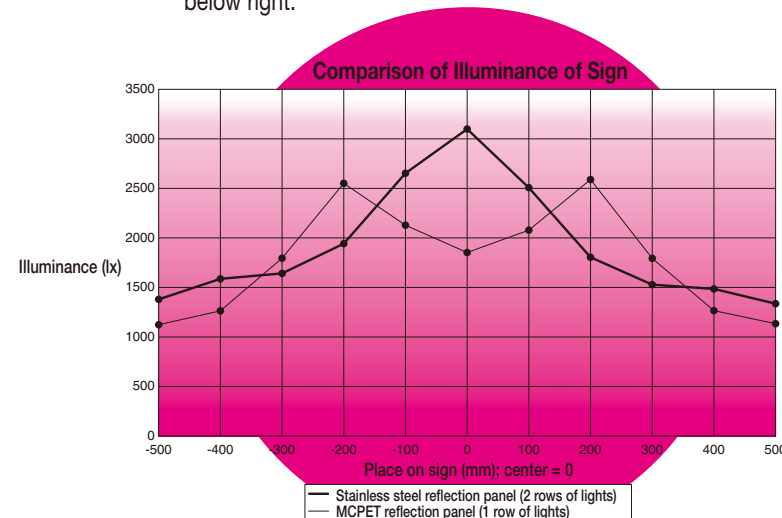

### 1. Fluorescent Lights Reduced 30% (per 2m<sup>2</sup>, 1.5m x 1.2m)

	Fluorescent wattage	Lights	Row pitch (mm)
Current methods	40 watts	7	200 pitch
MC-PET	40 watts	5	300 pitch

### 2. For lights on 20 hours per day, annual energy costs can be cut 7,300 yen per square meter.

Energy savings (per 2m<sup>2</sup>) ..... 2 x 40 - watt fluorescent lights

Energy savings per day  
40 watts x 2 lights x 20 hours per day = 1,600 watt-hours per day

Energy savings per year  
1.6 x 25 yen x 365 days = 14,600 ..... 14,600 yen per 2m<sup>2</sup>  
14,600 / 2m<sup>2</sup> = 7,300 ..... 7,300 yen

## 3 Illumination blurs (striped patterns of lamps) are reduced. Please consult us for blurs related to especially thin signs (under 40 mm).

In general, when the distance between the lamps and the sign surface is short, the areas immediately above the lamps are overly bright and the areas between lamps are dark, resulting in illumination blurs on the sign surface. Simply by using MCPET reflection panels, higher illuminance between lights results in a more balanced lighting effect and a reduction in blurs and striping. For especially thin signs where reducing the blurring effect is difficult, we have special methods to solve the problem. Please consult us for details.

Stripe patterns caused by internal lights are sharply reduced.

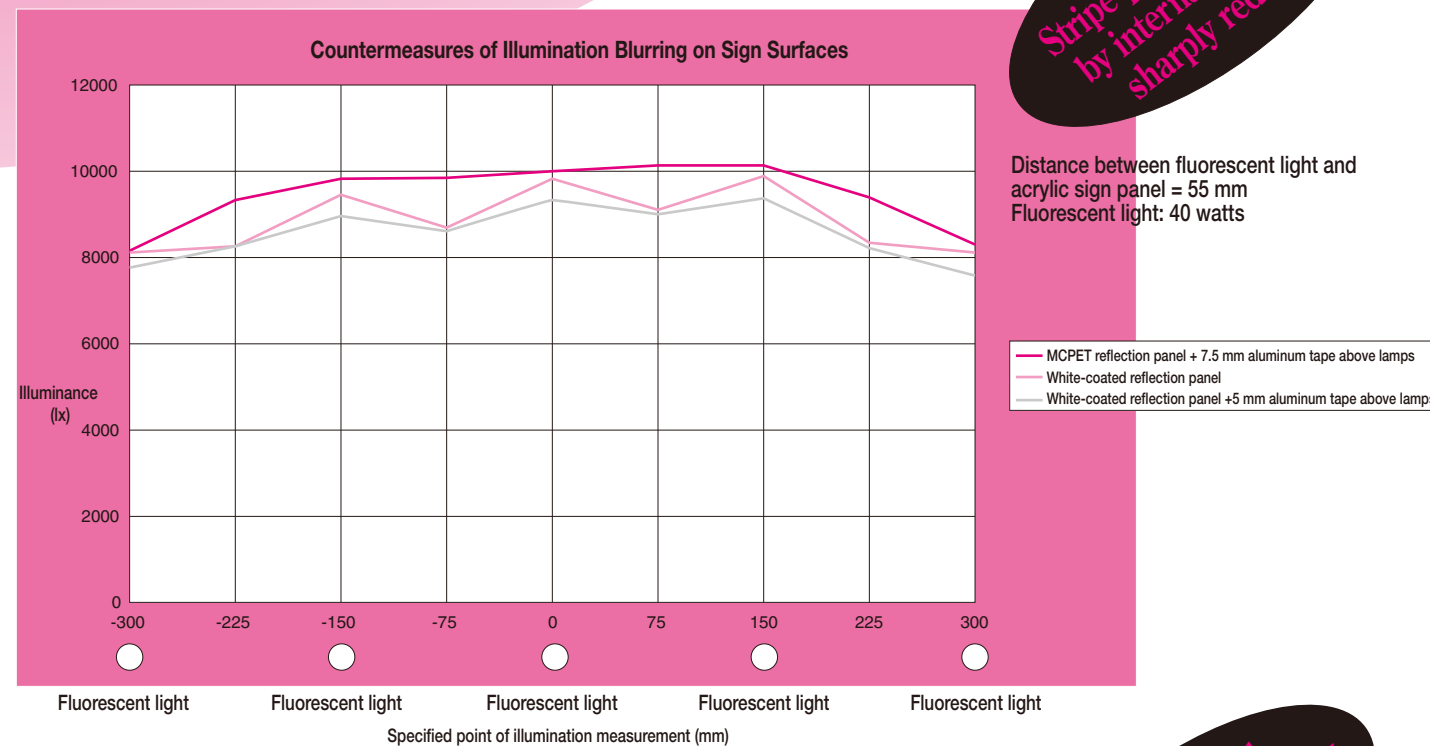

Processing and installation is really easy.

## 4 Installation is easy with a cutter knife. MCPET panels can be attached behind fluorescent lamps with special two-sided adhesive tape.

We recommend the following two-sided tape.  
Manufacturer: Sumitomo 3M Ltd. Product name: VHB™ Double Coated Foam Tape

Tape	Product No.	Thickness Tape	Color	Basic Material		Adhesive	Liner	Temperature Resistance (Note) Exterior
				Material	Grade			
General use	Y-4950	1.14	White	Acrylic foam	Regular	Acrylic	Paper	-20 to 150 °C

## 5 Maintenance

Although MCPET is treated with an anti-static process, we recommend cleaning once per year to maintain long-term function.

## 6 Can be used with various types of products

### Illuminated box and luminous ceiling

#### Conventional structure

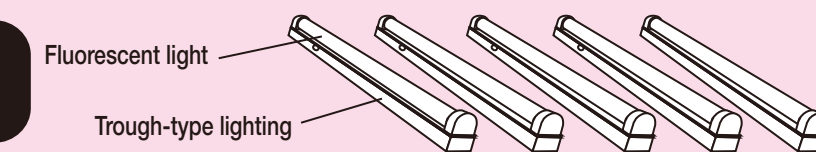

Increasing brightness by 60%  
Uneven light output is eliminated

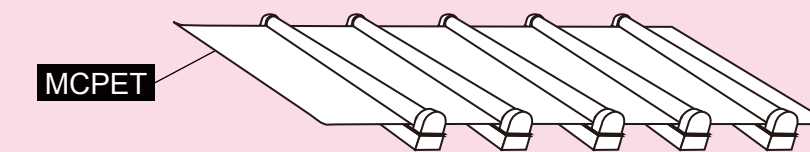

Saving energy by 40%  
Same level of illuminance is maintained

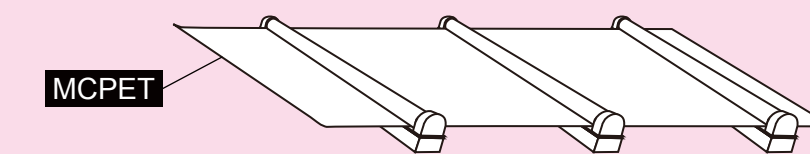

\*Installed upside down for luminous ceiling.

### Ceiling light

#### Using MCPET

Two fluorescent lights can provide the same brightness as three or more conventional fluorescent lights.

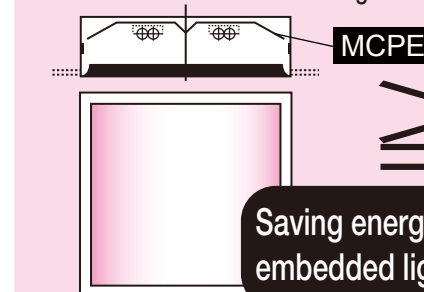

#### Conventional type

Steel panel with white coating is used for the reflector. Conventional products

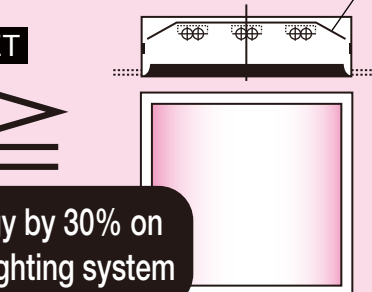

Saving energy by 30% on embedded lighting system

Furthermore, using an energy-saving fluorescent light can save energy by 70% in total.

### Showcase

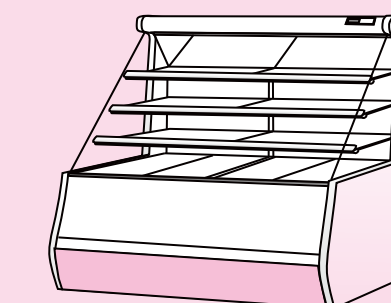

Increasing illuminance by 30%

Increasing illuminance of a showcase

### Double-sided signboard

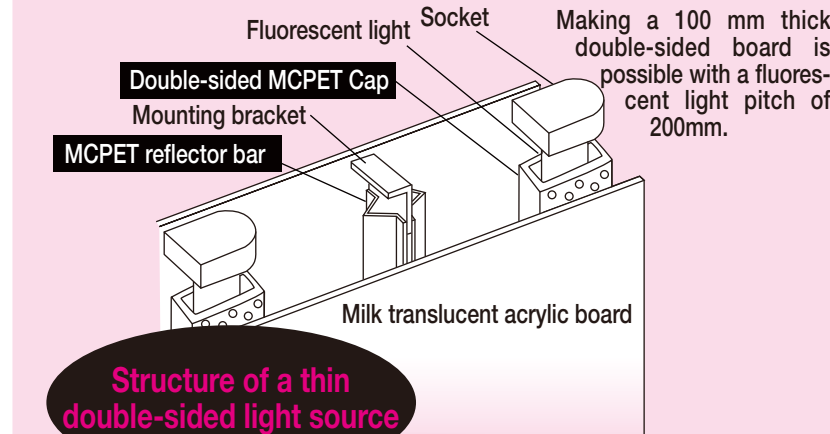

Structure of a thin double-sided light source